

LVDT

Inductive Position Transducer - Hydraulic Series



Series Hydraulic

- *position measurement in hydraulic cylinders of machine controls*
- *ranges 2...180 mm*
- *temperature -40...+120 °C (150 °C optional)*
- *pressure up to 400 bar*
- *output: AC, 0...10 V, 0...5 V, 4...20 mA, 0...20 mA, ±10 V, ±5 V*
- *linearity up to 0,20 %*
- *stainless steel flange (V4A)*
- *different flange types*
- *customised versions available*

DESCRIPTION

The sensors are used in hydraulic cylinders with a maximum pressure resistance of up to 400 bar. They are especially suited to be employed in harsh industrial environments where a high electromagnetic tolerance is required. The sensor works nearly unaffected by electrical or magnetical fields.

This sensor enables a connection of the hydraulic cylinders and machine controls.

Customised versions with different measurement ranges and flange types are available.

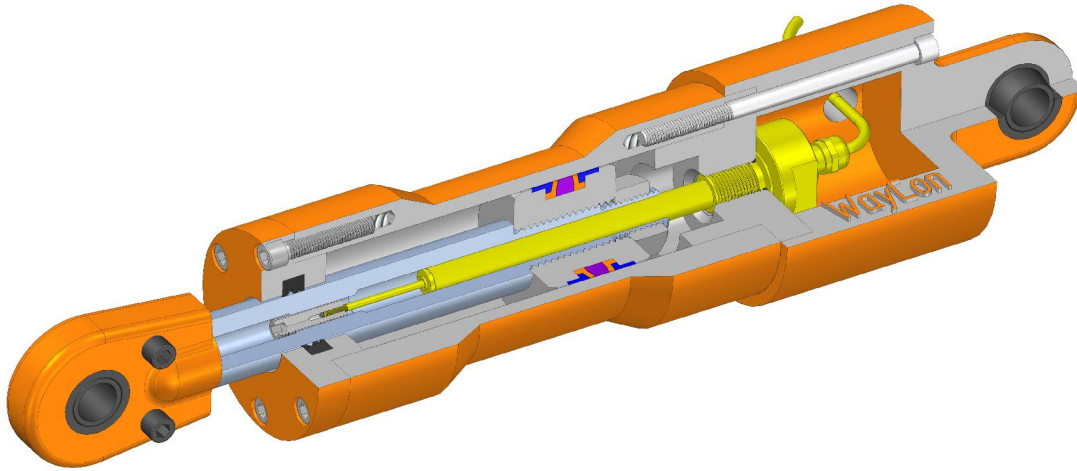

TECHNICAL DATA

sensor

ranges [mm]	2...180 mm (see chart on page 3)
linearity [% of FS]	±0,20 % - 0,80 % (see chart on page 3)
temperature range	-40...+120 °C, optional up to 150 °C (H-option)
vibration stability DIN IEC68T2-6	10 G
shock stability DIN IEC68T2-27	200 G/ 2 ms
connection	4 core cable or M12-connector with coupling nut
cable TPE (standard)	ø 4,5 mm, 0,14 mm ² , non-halogen, suitable for drag chains
PTFE (option H)	ø 3,6 mm, 0,24 mm ² , max. temperature 205 °C
max. cable length	100 m between sensor and electronics

electronics

IMCA external electronics (built-in)

KAB cable electronics

output signal	0...20 mA, 4...20 mA (load <100 Ohm) 0...5 V, ± 5 V (load >5 kOhm) 0...10 V, ± 10 V (load >10 kOhm)	4...20 mA (load <100 Ohm) 0...5 V, ± 5 V (load >5 kOhm) 0...10 V, ± 10 V (load >10 kOhm)
temperature coefficient	zero 150 ppm/ °C, max. value 400 ppm/ °C	460 ppm/ °C
ripple	< 0,5 mV _{eff} up to 300 Hz, < 4 mV _{eff} up to 20 MHz	< 0,5 mV _{eff} up to 300 Hz, < 4 mV _{eff} up to 20 MHz
max. frequency	300 Hz/ -3 dB (Bessel, 6-pole)	300 Hz/ -3 dB (Bessel, 6-pole)
isolation voltage	> 1000 VDC	> 1000 VDC
power supply	9...36 VDC	9...36 VDC
current consumption	75 mA at 24 VDC 150 mA at 12 VDC	65 mA at 24 VDC 140 mA at 12 VDC
sensor supply	3 V _{eff} , 3 kHz (adjustable 1-18 kHz)	3 V _{eff} , 3 kHz (adjustable 1-18 kHz)
working temperature	-40...+85 °C	-40...+85 °C
storage temperature	-40...+85 °C	-40...+85 °C
housing	polyamide PA6.6, meets UL94-VO	aluminium
mounting	on DIN EN-rail	-

TECHNICAL DATA / DIMENSIONS

range (FS) [mm]	type	body length A [mm]	linearity [%] (standard)	linearity [%] (optional)
0...2	SM2-HYD	48	0,30	0,20
0...5	SM5-HYD	54	0,30	0,20
0...10	SM10-HYD	64	0,30	0,20
0...25	SM25-HYD-M	94	0,30	0,20
0...25	SM25-HYD	137	0,30	0,20
0...50	SM50-HYD-M	144	0,30	0,20
0...50	SM50-HYD	207	0,30	0,20
0...100	SM100-HYD-M	220	0,80	-
0...120	SM120-HYD	227	0,80	-
0...140	SM140-HYD	260	0,80	-
0...160	SM160-HYD	336	0,80	-
0...180	SM180-HYD	300	0,80	-

flange type with thread M18 x 1,5

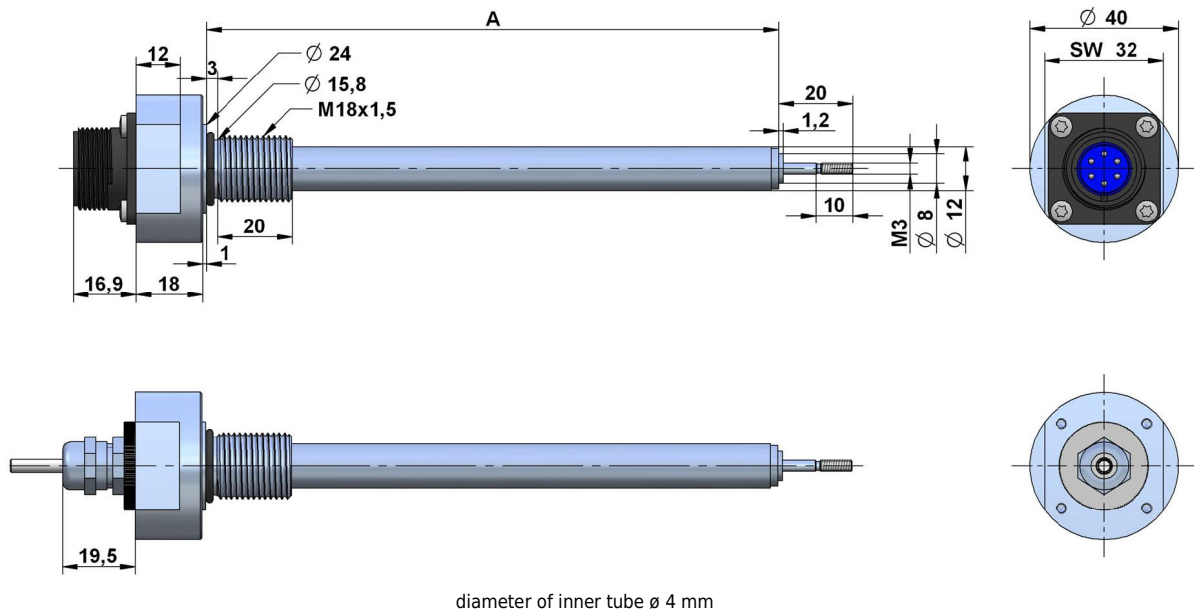

flange type with thread M30 x 1,5

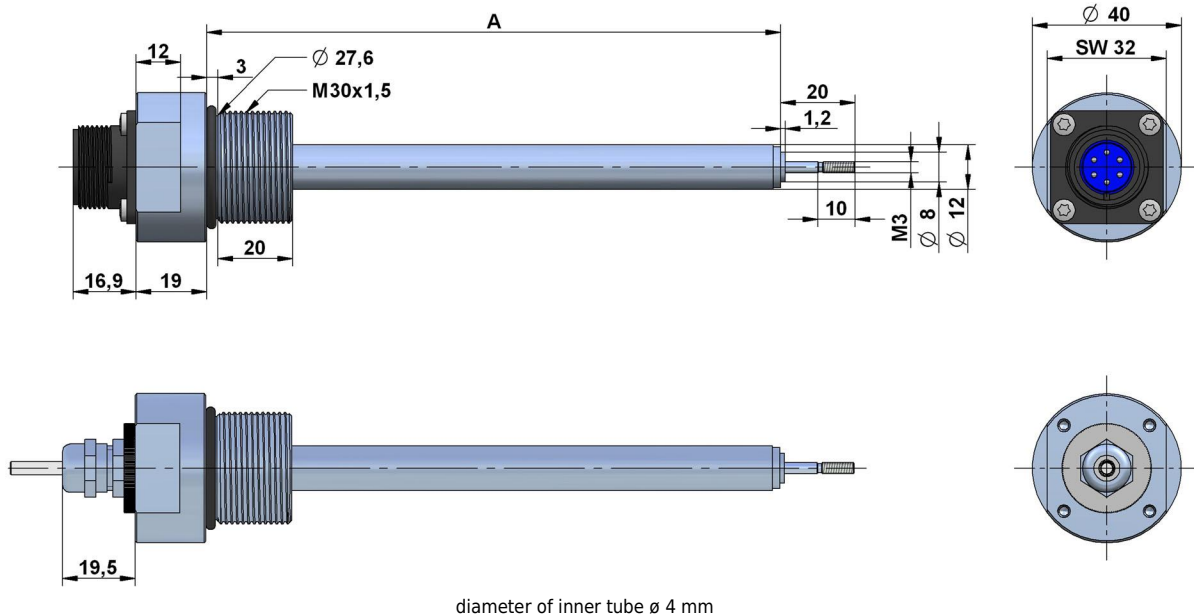

INSTALLATION DRAWING

flange with thread M18

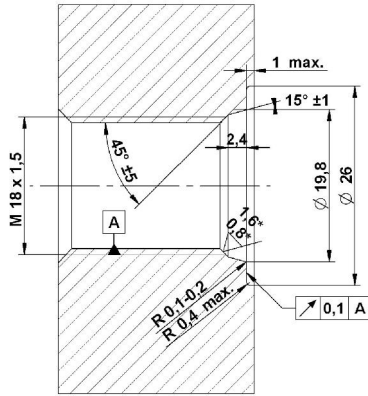

* note: Rz = 1,6 for non pulsating pressure
Rz = 0,8 for pulsating pressure

flange with thread M30

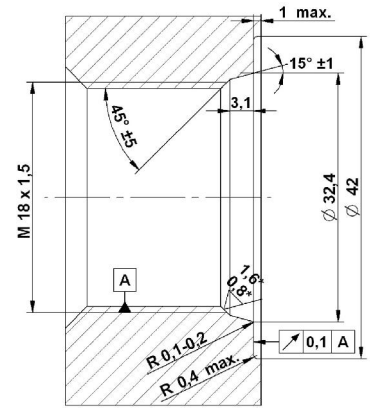

* note: Rz = 1,6 for non pulsating pressure
Rz = 0,8 for pulsating pressure

AC-OUTPUT

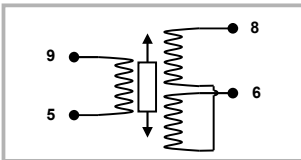

assignment for TPE-cable:

white (5): primary 2
black (6): secondary 2
brown (9): primary 1
blue (8): secondary 1

assignment for PTFE-cable:

white (5): primary 2
green (6): secondary 2
yellow (9): primary 1
brown (8): secondary 1

CABLE ELECTRONICS KAB



cable length sensor-electronics
1m, 4m, 9m

cable length 1m

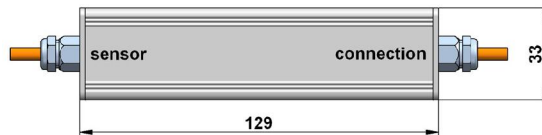

assignment for TPE-cable:

brown: supply V+
blue: GND
black: output GND
white: output signal

assignment for PTFE-cable:

yellow: supply V+
brown: GND
green: output GND
white: output signal

If not specified otherwise the cable electronics is placed at 1 m from the end of the cable. On request in your order, however, the cable electronics can be placed at any position.

EXTERNAL ELECTRONICS IMCA

dimensions:



external electronics IMCA
(for DIN-rail mounting)

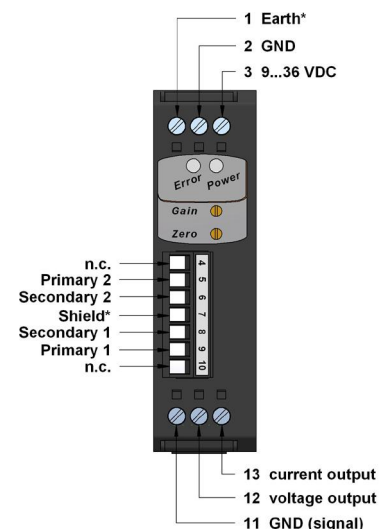
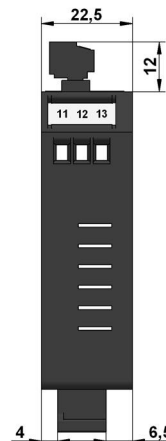
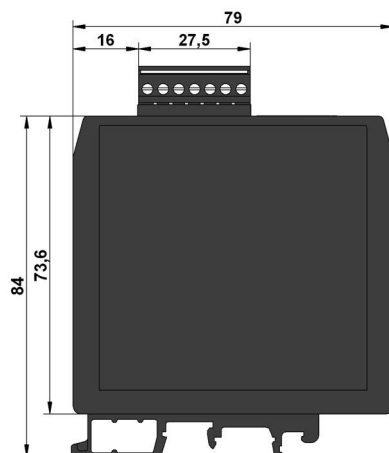

* Terminals 1 and 7 are internally connected.

Connection

The external electronics IMCA is designed to be installed in switch cabinets (Din-rail mounting). The connection to the sensor is conducted as connector with screw terminals.

CONNECTION

pin assignment

Pin A: primary 1
Pin B: primary 2
Pin C: secondary 1
Pin D: secondary 2

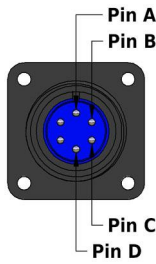

mating connector: AT3106F 14S-6S
(bitte extra bestellen)

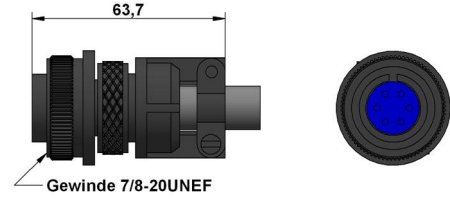

At harsh EMC environments, it is possible to install the electronics at a max. distance of 100 m in a switch cabinet. A twin twisted pair cable (4-cores, minimum cross section 0,5 mm²), single or double shielded, is to be used for the further wiring to connect the external electronics to the system. It is recommended to ground the shield in the switch cabinet near the electronics (do not ground at the machine/ sensor). The sensor housing is grounded at the machine frame. To prevent interference, the cable length should not exceed 100 m.

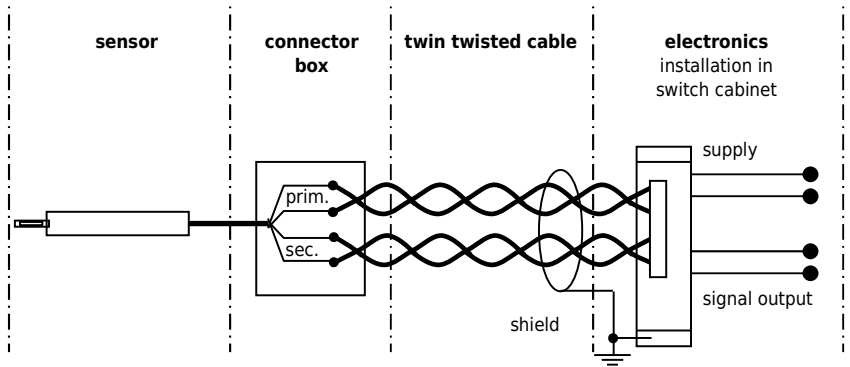

ADJUSTMENT OF ZERO POINT AND GAIN

Please note that the zero point and gain may shift for long cable length between sensor and electronics. Thus install the sensor with the according cable length to the electronics and then adjust zero point and gain.

1. Push rod entirely in - adjust offset
Move the sensor to the zero point of the measuring range and set the offset potentiometer on 0 mA / 0 V for the output signal.
2. Push rod entirely out - adjust gain
Move the sensor to the end of the measuring range (push rod moved out) and set the gain potentiometer on 16 mA / 10 V / 5 V for the output signal.
3. Adjust offset (4...20 mA output only).
Set the offset potentiometer on 20 mA (+4 mA) for the output signal.

Signal inversion:

If an inverted output signal is required (20...4 mA / 10...0 V / 5...0 V), swap clamps 6 and 8 (secondary coil) on the external electronics.

ORDER CODE

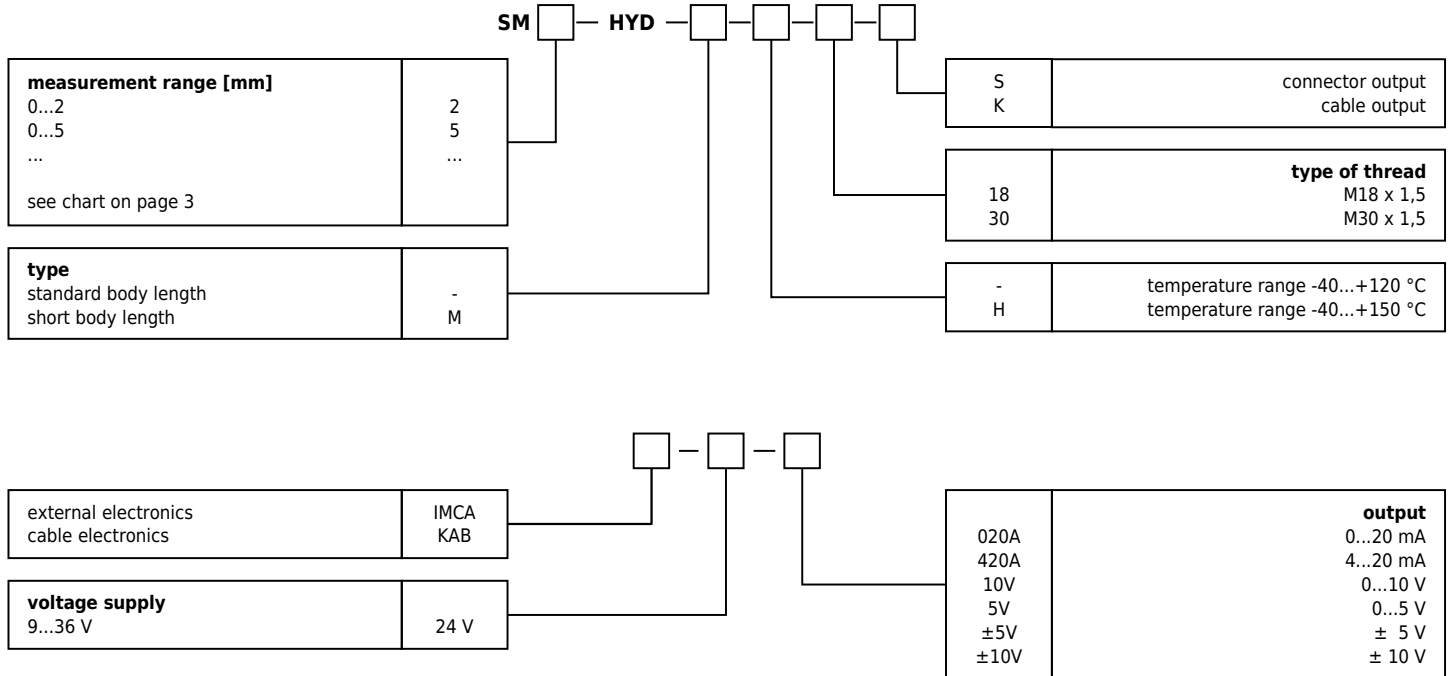

Connector cable:

fixed connector cable (2,0 m standard, KA, KR):
 additional metre of TPE-cable
 additional metre of PTFE-cable (-H)

mating connector AT3106F